



ViperJET
75mm EDF

NOTICE

Thank you for purchasing this HSD product. Please read this manual carefully before operating this plane. We hope this manual is useful in guiding you through the installation and adjustment of the plane so that you may successfully fly it.

Each product from HSD has unique functions that users will need to fully grasp step by step as you will complete the assembly. It is necessary to assemble and test the product strictly in accordance with HSD's standards.

All rights reserved by HSD for the upgrade and/or reconfiguration of products.

Meaning of Special Language:

The following terms are used throughout the product manual to indicate various levels of potential harm when operating this product:

NOTICE: If procedures are not properly followed, the risk of physical property damage AND a possibility of serious injury are likely.

CAUTION: If procedures are not properly followed, the risk of physical property damage AND a possibility of serious injury are likely.

WARNING: If procedures are not properly followed, the risk of physical property damage AND a possibility of serious injury are likely.



WARNING: Read this instruction manual entirely to become thoroughly familiar with the features of the product before operating. Failure to operate the product correctly can result in damage to the product or personal property and it can cause serious injury.

This is a sophisticated hobby product. It must be operated with caution, common sense, and requires some basic mechanical ability. Failure to operate this product in a safe and responsible manner could result in physical injury or damage to the product or other property. This product is not intended for use by children without direct adult supervision. Do not use with incompatible components or alter this product in any way contrary to the instructions provided by HSD HOBBY LTD. This manual contains instructions for safety, operation and maintenance. It is essential to read and follow all the instructions and warnings in the manual prior to assembly, setup or use, in order to correctly operate the product and/or avoid damage or serious injury.

14+ AGE RECOMMENDATION: Not for children under 14 years of age. This is not a toy.

Safety Precautions and Warnings

As the user of this product, you are solely responsible for operating it in a manner that does not endanger yourself and/or others or result in damage to the product and property of others.

- ◇ Always keep a safe distance, in all directions, around your model to avoid collisions or injury. This model is controlled by a radio signal subject to interference from many sources outside of your control; interference can cause momentary loss of control.
- ◇ Always operate your model in open spaces away from full-size vehicles, traffic and people.
- ◇ Always carefully follow directions and warnings for this model, and any optional support equipment (i.e., chargers, rechargeable battery packs, etc).
- ◇ Always let parts cool down, after use, before touching or to use again.
- ◇ Always keep all chemical, small and electric parts, out of children's reach.
- ◇ Always avoid water exposure to all equipment that is not specifically designed for this purpose as moisture causes damage to electrics.
- ◇ Never operate your model with low transmitter batteries.
- ◇ Always keep aircraft in sight and under control.
- ◇ Always keep the transmitter on for as long as the aircraft is in use.
- ◇ Always remove batteries after use.
- ◇ For your safety, do not touch moving parts.
- ◇ Never operate aircraft with damaged wires.
- ◇ Always ensure failsafe is properly set before flying.

Charging Warnings

CAUTION: All instructions and warnings must be followed exactly. Mishandling of Li-Po batteries can result in a fire, personal injury, and/or property damage.

- By handling, charging, or using the included Li-Po battery, you assume all risks associated with lithium batteries.
- If, at any time, the battery begins to balloon or swell, discontinue use immediately. If charging or discharging, discontinue and disconnect. Continuing to use, charge, or discharge a battery that is ballooning or swelling can result in a fire.
- Always disconnect the battery after charging, and let the charger cool between charges.
- Always consistently monitor the temperature of the battery pack while charging.
- Never attempt to dismantle or alter the charger.
- Never allow minors under the age of 14 to charge battery packs.
- Never discharge Li-Po cells to below 3V under load.
- Never cover warning labels with hook and loop strips.
- Never leave charging batteries unattended.
- Never charge batteries over recommended levels.
- Never charge batteries in extremely hot or cold places.
- Do not store battery or aircraft in a car or direct sunlight. If stored in a hot car, the battery can catch fire or be damaged.
- Always store the battery at room temperature in a dry area for best results.
- **ONLY USE A CHARGER SPECIFICALLY DESIGNED TO CHARGE LI-PO BATTERIES.** Failure to charge the battery with a compatible charger may cause fire, resulting in personal injury and/or property damage.

CONTENTS

Box Content	1
Specifications	1
Assembly	2
Control Horn and Servo Arm Settings	3
Control Direction Test	4
Clevis Installation	5
Control Surface Centering	5
Throttle Range Setting	5
CG Configuration	6
Battery Installation	6
Accessories	7
Troubleshooting	9
Flight Precaution	10
Pre-flight Check	10







Attention

EDF jets require Li-PO batteries with a high discharge rating (C rating) for increased safety and optimal performance. We recommend using Li-Po batteries with a minimum of 40C or above.

Box Contents



Specifications

	75mm EDF	PNP
	Brushless Outrunner Motor 3060/2600KV (4S) 3060/2000KV (6S)	Installed
	Hobbywing 60A Pro BrushlessESC (2-6S)	Installed
	Six analog 9g servos	Installed
	Battery: 4S 2200mAh-3300mAh 40C Li-Po 6S 2200mAh-3300mAh 40C Li-Po	Required to Complete
	Radio System: 2.4GHz 4CH Transmitter and Receiver	Required to Complete

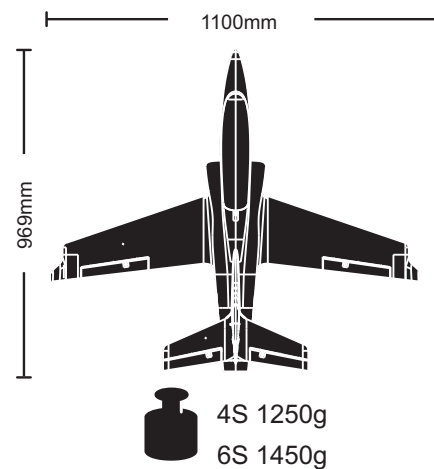

Assembly

1 Connect the servo link and fix the screws

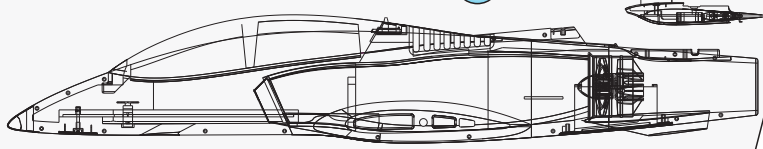

PA 3*15MM 1pcs
PA 3*18MM 1pcs

2 Connect the servo link and fix the screws

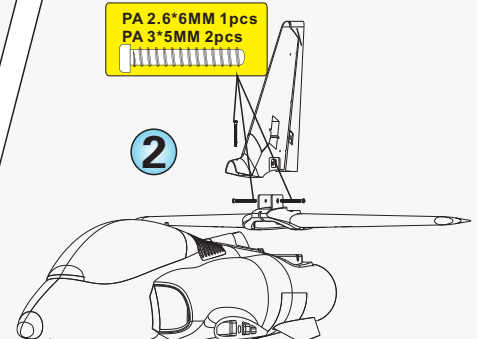

PA 2.6*6MM 1pcs
PA 3*5MM 2pcs

3

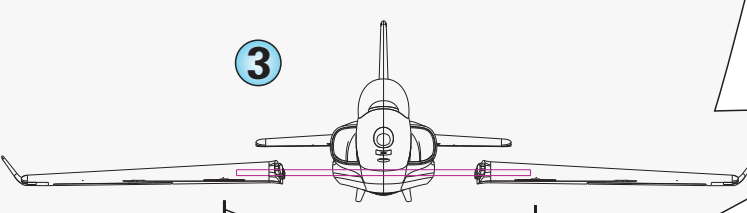

Fixed with screws
PA 2.6*6MM 2pcs

4

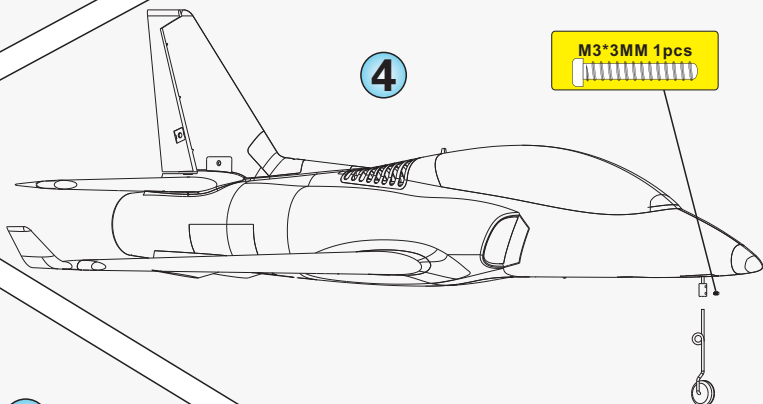

M3*3MM 1pcs

5

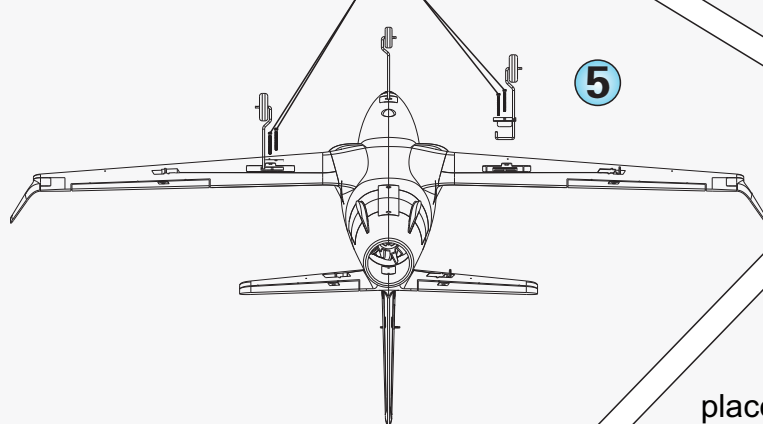

PA 2.6*6MM 4pcs

Assembly is now complete.

6 Make sure that all screws and bolts are secure and firmly in place before proceeding to the next pages.

Control Horn and Servo Arm Settings

The table below shows the factory settings for the control horns and servo arms. Fly the aircraft at factory settings before making any modifications. After flying you may choose to adjust the linkage positions for the desired control response. See the lower table.

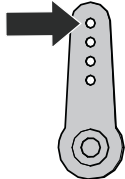
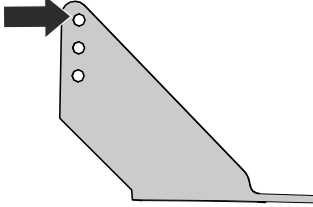
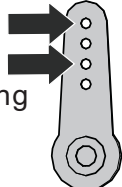
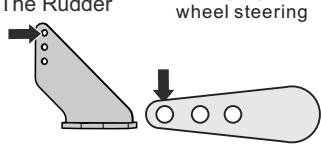
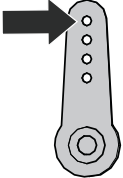
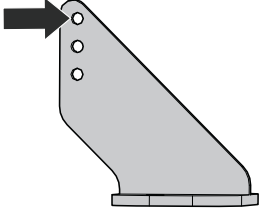
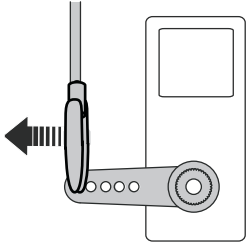
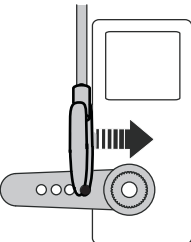
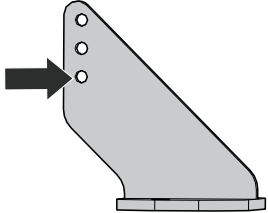
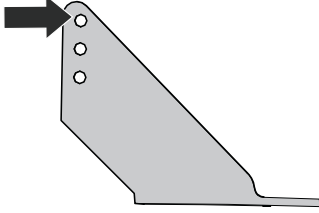
	Horns	Arms
Elevator		
Rudder	<p>The Rudder →</p> <p>The front wheel steering →</p> 	<p>The Rudder →</p> <p>The front wheel steering ↓</p> 
Ailerons		
Increased Thrust Control		Decreased Thrust Control
		
		

Control Direction Test

Assemble the aircraft and bind your transmitter to the receiver before performing this test. After binding a transmitter to the aircraft receiver, set the trims and sub-trims to 0, then adjust the clevises to center the control surfaces. Move the controls on the transmitter to make sure the aircraft control surfaces move in the proper direction.

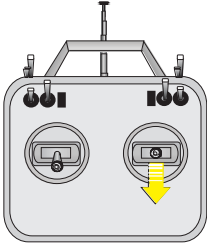
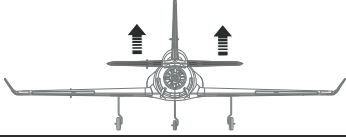
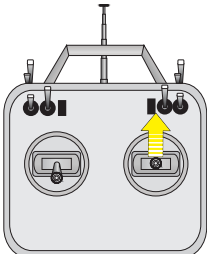
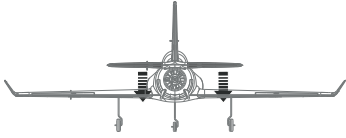
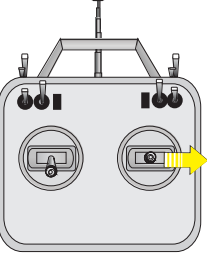
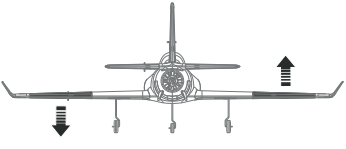
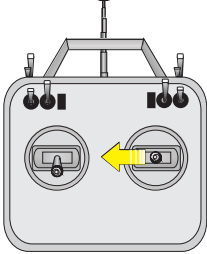
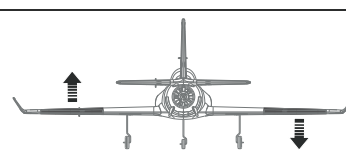
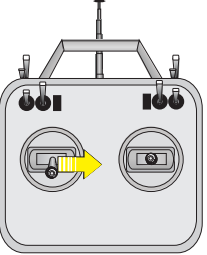
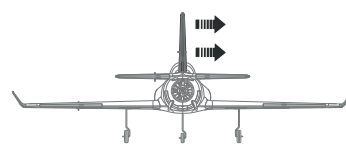
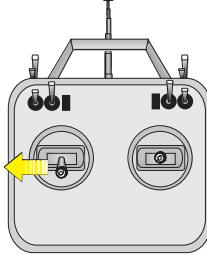
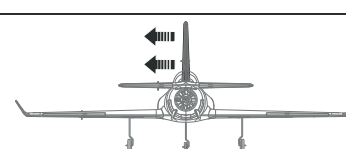
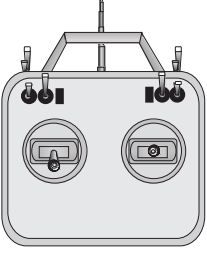
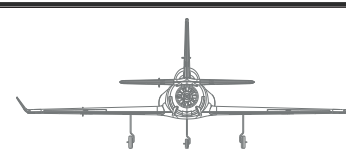
		Transmitter Command	Aircraft Reaction		
	Elevator	Move right stick down			
		Move right stick up			
	Aileron	Move right stick right			
		Move right stick left			
	Rudder	Move left stick right			
		Move left stick left			
	Throttle	Move left stick up/down			

Clevis Installation

- *Adjust the push rod and clevis as necessary
- *Carefully adjust the clevis so that it creates a centered surface when attached to the control horn.

Control Surface Centering

- *After assembly and transmitter setup, verify that the control surfaces are centered. If the control surfaces are not centered, manually center the control surfaces by adjusting the linkages.
- *With the flaps switch in the up position, flaps should be adjusted so that they are even with the ailerons/root of the wing.
- *If adjustments are required, turn the ball buckle on the push rod to change the length of the linkage between the servo arm and the control horn. After binding the transmitter to the receiver, set the trim and sub-trims to 0, then adjust the ball buckles as necessary to center the control surfaces.

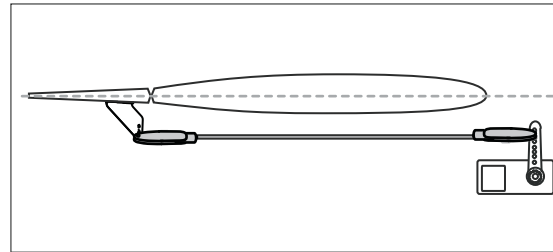
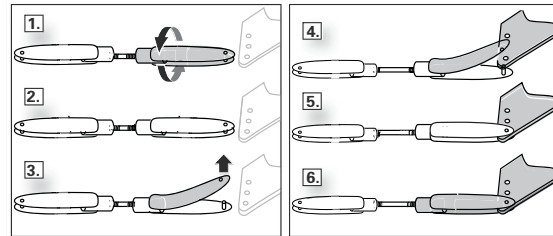

Throttle range setting

(Throttle range should be reset whenever a new transmitter is being used)

Step 1: Switch on the transmitter and move the throttle stick to 100% (wide-open throttle)

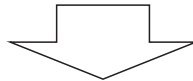

Step 2: Connect the battery pack to the ESC, and wait about 2 seconds

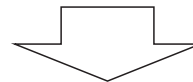

Step 3: A 'beep-beep' tone will emit, this means the highest point in the throttle control range has been confirmed

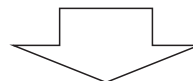

Step 4: After the 'beep-beep' tone is emitted, move the throttle stick back down to the lowest position (0%). You will then hear a set of initialization beeps that register the number of cells in the battery

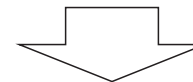

Step 5: A final long beep tone should sound, meaning that the lowest point of the throttle range has been confirmed. This means the throttle control has been initialized properly and is ready for use

CG Location

Make sure the center of gravity (CG) is as indicated in the following diagram:

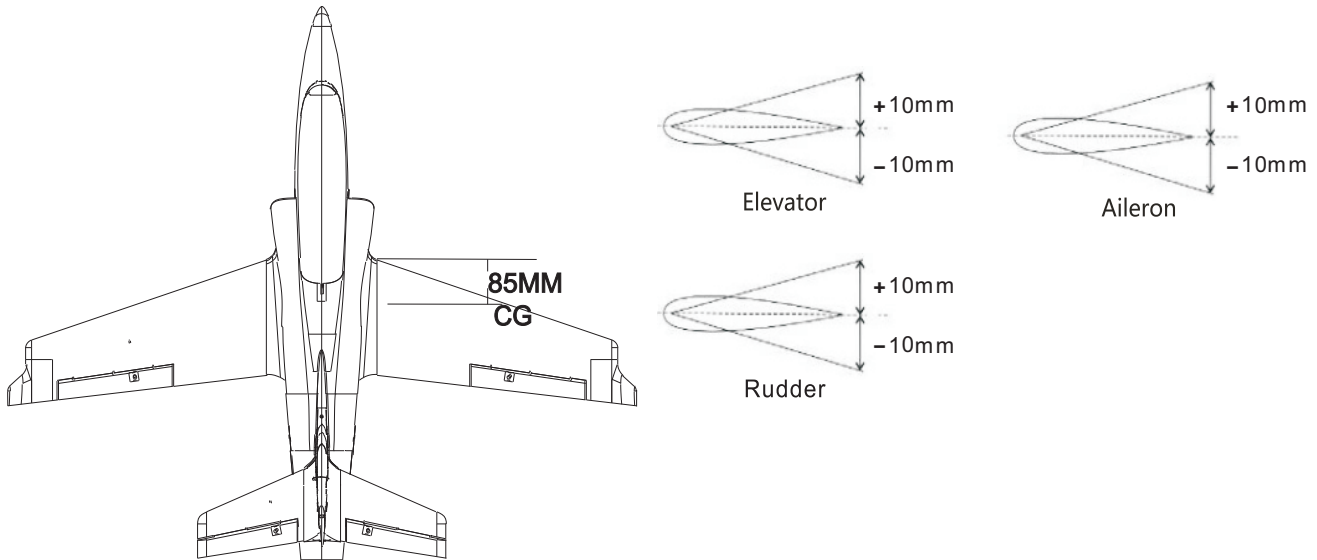

Battery Installation

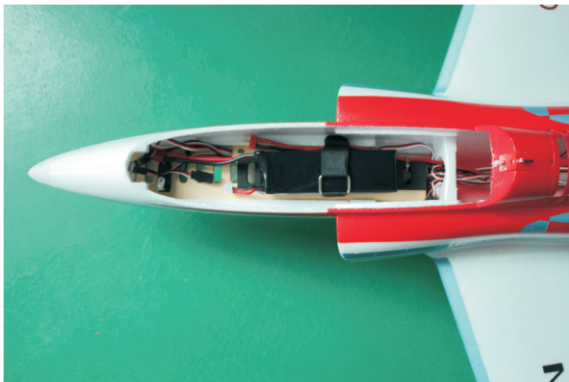

**Recommended battery location for
4S 3300mAh (350g) Li-Po**

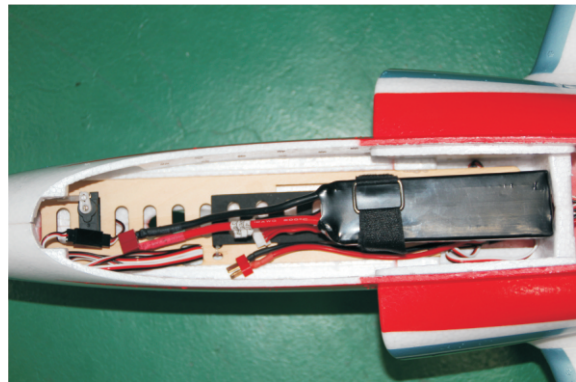

**Recommended battery location for
6S 3300mAh (550g) Li-Po**

Accessories



HSDA75-T01



HSDA75-T02



HSDA75-T03



HSDA75-T04



HSDA75-T05



HSDA75-T01135



HSD-TB02



HSD-BB01



HSD-BA02



HSD-BA01

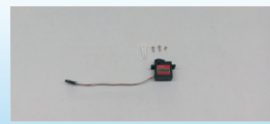

HSD-BC01

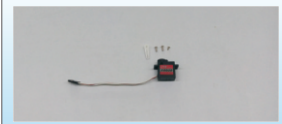

HSD-BC02

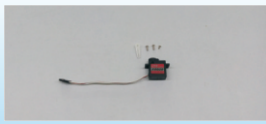

HSD-BC03

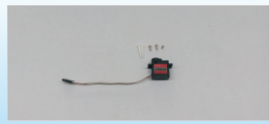

HSD-BC04



HSD-TM01



HSD-TD01



HSD-TD02



HSDA75-T06



HSD-M02



HSDA75-TA01

Accessories continued

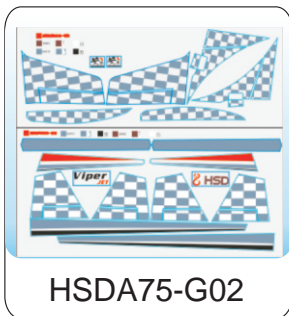
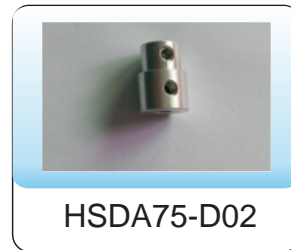
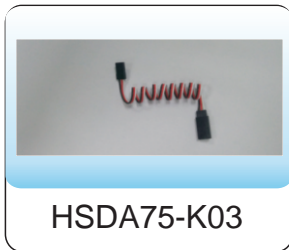
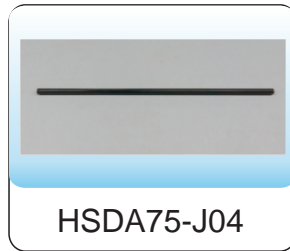
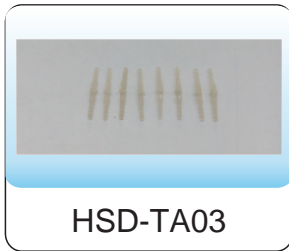
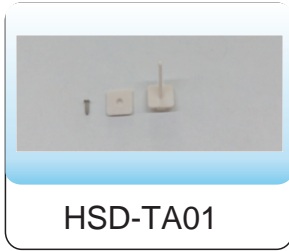

Troubleshooting

Problem	Probable Causes	Solutions
Motor does not run	<ol style="list-style-type: none"> 1. Battery is not fully charged 2. Transmitter battery is low 3. Motor is not connected 4. Motor is damaged 5. Receiver not bound to the transmitter 6. ESC needs to be calibrated 	<ol style="list-style-type: none"> 1. Charge the battery 2. Install fresh AA batteries 3. Check for connection between the ESC and motor 4. Replace motor 5. Consult radio manual and go through bind procedure 6. Hold model and move throttle to full position then back down to idle
Model moves backwards	Both ESC and motor are not establishing a proper response range	Locate the three (3) connections between the motor and ESC, disconnect two (2) of the three (3) and swap their places for proper response
Control surfaces are not responding to stick input	<ol style="list-style-type: none"> 1. Servo lead may be connected to the receiver incorrectly 2. The servo is damaged 	<ol style="list-style-type: none"> 1. Make sure servo leads are properly connected to receiver 2. Replace the servo
Model is flying erratically	<ol style="list-style-type: none"> 1. Control surfaces are not centered 2. Control surfaces are severely off-centered 3. Center of gravity (CG) not in the correct position 	<ol style="list-style-type: none"> 1. Make trim adjustments as necessary on transmitter 2. Make manual adjustments as necessary to the surface control linkages 3. Reposition the battery as necessary to achieve CG
Model does not climb well	<ol style="list-style-type: none"> 1. Battery is not fully charged 2. Elevator surface response is reversed 3. CG is too far back, causing a tail-heavy airframe 	<ol style="list-style-type: none"> 1. Recharge the battery within the specified charge time 2. Charge the surface direction via the reverse function on the transmitter 3. Reposition the Li-Po battery as necessary to achieve a balanced CG
Limited radio range	Transmitter or receiver power is low	Charge or replace any batteries used on the transmitter and receiver (if applicable)

Model Flying Precautions

- ✧ Select your flight area carefully. Always choose an open space that is unobstructed by trees and/or buildings and away from crowded area. Avoid flying in area with roads, electricity/telephone poles or wires and water nearby or within close proximity to air traffic.
- ✧ Do not fly this model in poor weather, high winds, low visibility, extreme temperatures, rain and storms.
- ✧ Never attempt to catch this model whilst in flight. Even a slow moving model cause harm to yourself and to others. This also poses a risk in damage to this model.
- ✧ This model is recommended for children no younger than 14 years old. All children, no matter what age, should always be supervised by a capable and responsible adult when operating this model.
- ✧ Always unplug your model battery when not in use. Never leave the battery installed in the model.
- ✧ Please remember to keep clear of the propeller at all times when your flight battery is connected.
- ✧ Before flying, always turn on your transmitter first then plug your flight battery into the model.
- ✧ After flying, always unplug your battery first then turn off your radio transmitter.
- ✧ Exercise caution when charging your batteries and follow your battery manufacturer's safety guideline when doing so.

Pre-flight Checks

1. Always perform a range check before any flight (especially when flying a new model for the first time). Follow your radio manufacturer's guidelines to perform this check.
 2. Check that all screw/bolts and mounting points are firmly secured, including control horns and clevises.
 3. Only fly with fully charged batteries (both in your radio and model). Failure to do so could result in loss of control, damage to the model and/or persons/property around you. Check that your batteries are fully charged.
 4. With the model powered on (transmitter on first, then receiver/model) check that all surfaces are free from damage/obstructions, moving freely in the correct directions with stick input.
 5. Inspect the model and prop for any damage that may have occurred during transit and listen for any unusual sounds from the electronics when powered on. If in doubt, do not fly.
 6. If this is your first flight with the model double check that the CG is at the correct position. If not, adjust the battery position inside your model accordingly.
 7. If you are an inexperienced model pilot, seek the assistance of an experienced pilot to perform these final checks and to test fly the model for you.
-

ViperJET

75mm EDF

Distributed by:



Banana Hobby
California, USA
Call or Text (626) 629-8243
www.BananaHobby.com